



EXHIBITION TV STAND WITH ROTATING BRACKET FOR 32"-70" SCREENS

User Manual

SKU: DSTANDBK, CDSTANDBK,
DSTAND2BK, CDSTAND2BK



Scan the QR
code to visit the
product page.



Safety and Warning

 **CAUTION:** Severe personal injury and property damage can result from improper installation or assembly. Read the following warning carefully before assembly. If you have any questions regarding any of the instructions or warnings, please contact Displays2go.

- Tighten screws firmly, but do not over-tighten. Over-tightening can cause damage to the items, which greatly reduces their holding power.
- Make sure that the supporting surface will safely support the combined weight of the equipment and all attached hardware and components.
- This product is intended for indoor use only. Using this product outdoors could lead to product failure and personal injury.
- Always use an assistant or mechanical lifting equipment to safely lift and position the equipment.
- Do not use this product for anything other than the original design.
- This product contains moving parts, please use with caution.
- The manufacturer disclaims any liability for the modifications, improper installation, or installation over the specified weight range. The manufacturer will not be liable for any damages arising out of the use of, or inability to use, the product.



CAUTION: DO NOT EXCEED MAXIMUM LISTED WEIGHT CAPACITY. SERIOUS INJURY OR PROPERTY DAMAGE MAY OCCUR!



300x300/400x200
400x400/600x400

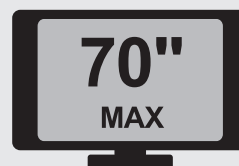

Base Assembly

Parts List (Base Package)

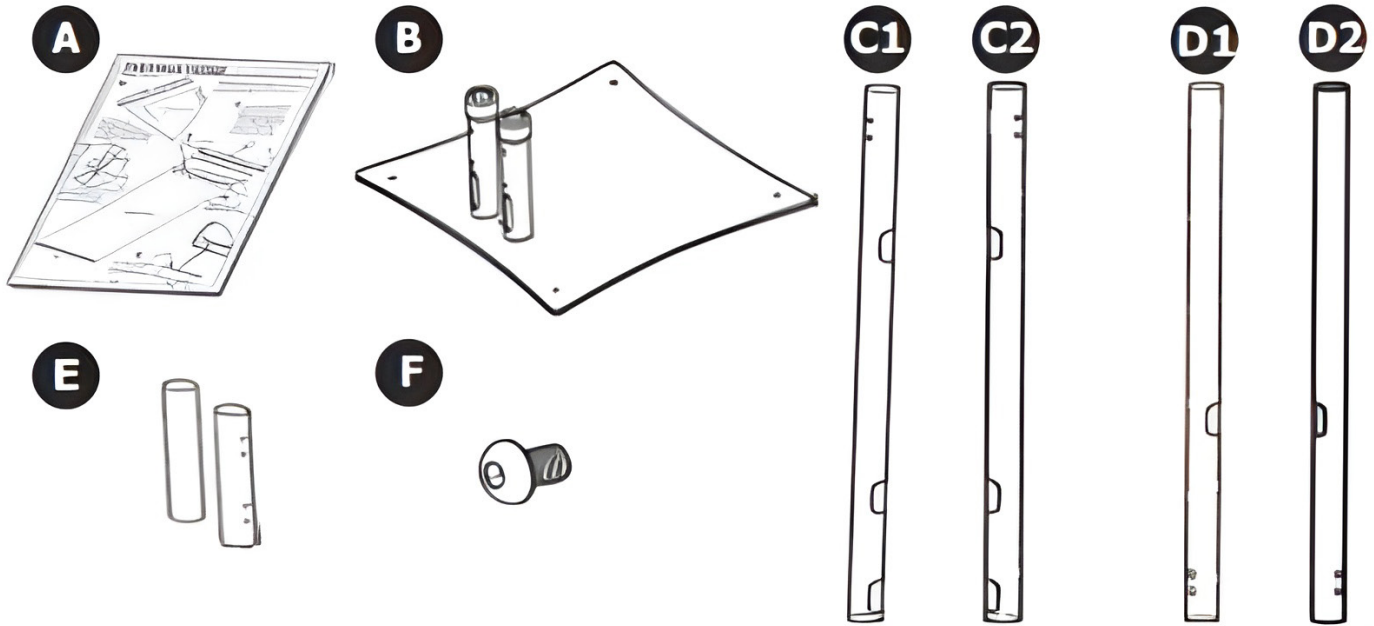

PART	QUANTITY
A: User Manual.....	1
B: Metal Base.....	1
C1: Lower Tubing (Left)	1
C2: Lower Tubing (Right).....	1
D1: Upper Tubing (Left).....	1
D2: Upper Tubing (Right)	4
E: Tubing Connector	2
F: Pan Head Screw	12

*Hex Wrench for Part F can be found inside the TV Bracket box. (DUOPOLEBK, DUOPOLESL)

! Instructions for Dual TV Head Stand (DSTAND2BK, CDSTAND2BK) can be found on page 8.

⚠ CAUTION: Heavy metal base can cause muscle strain or back injury! Two people required for assembling and moving unit.

If you have any questions regarding our products, please visit us at www.displays2go.com or contact Displays2go customer service at 844-221-3388.

Identify Parts

1. Identify all parts and lay out 4 tubings (C1, C2, D1, D2) on a flat surface. See picture below to identify position of each tubing (upper or lower, left or right).
 - Confirm each tubing has at least one pair of 2 holes facing outward (see detail 2).
 - Arrange tubings with one pair holes (see detail 3a), then sort tubings with two pairs holes (see detail 3b).

! NOTE: One or more upper/lower tubing may have holes on both sides.

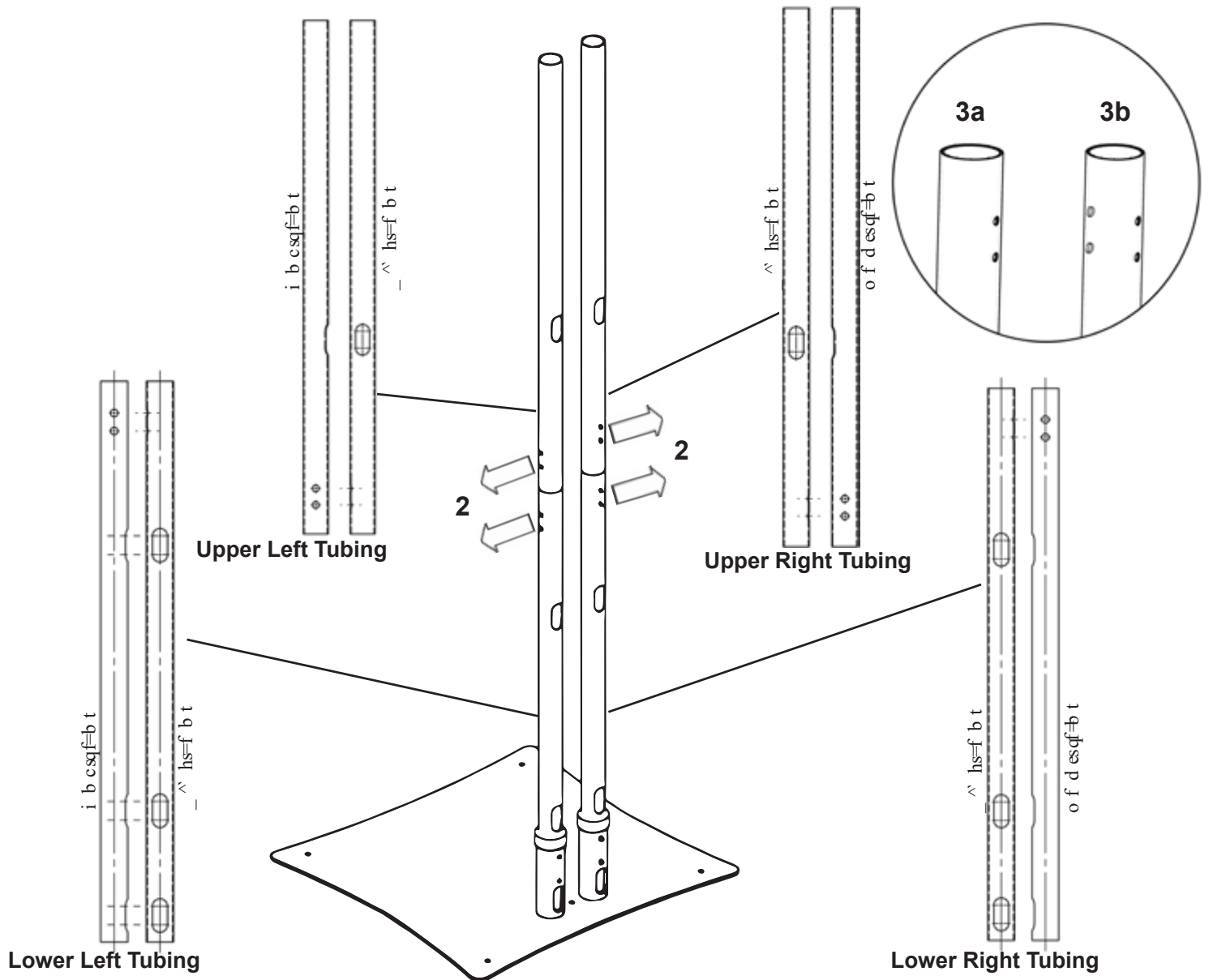

Place Lower Tubings

- Carefully place the metal base (B) on hard, flat ground.
- Insert left and right lower tubings (C) into the left and right upright slot on the metal base. Holes at top of lower tubings should face outward to align with the holes of tubing connectors later in assembly.

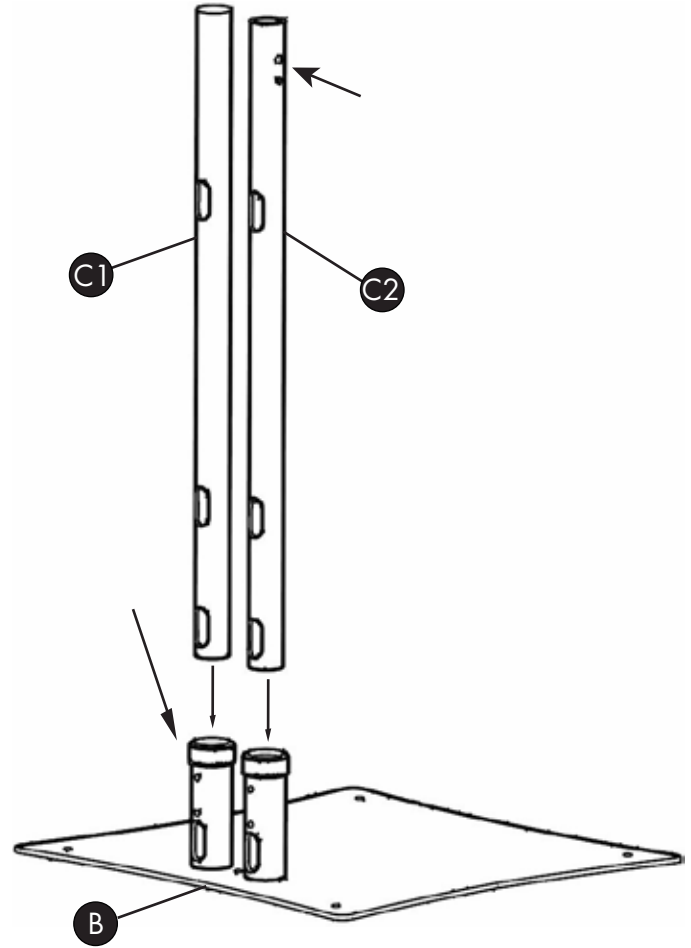

Fasten Lower Tubings

- Secure lower tubings to base using screws (F). Tighten with hex wrench.

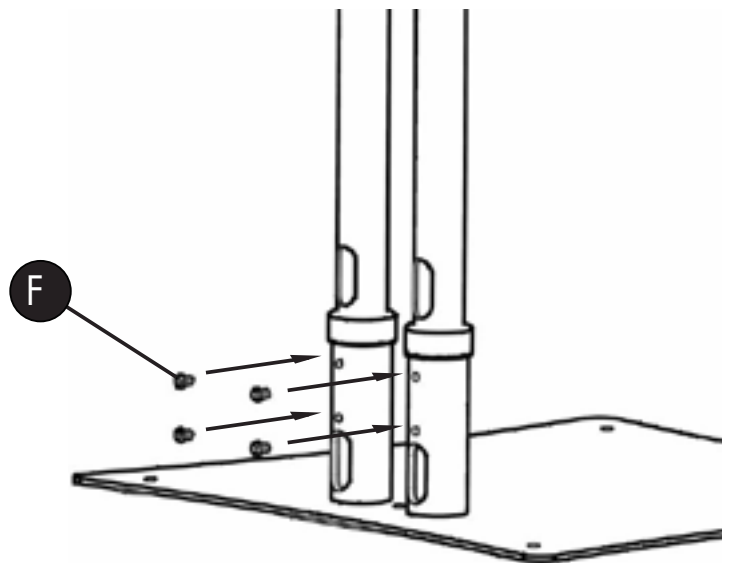

Place Upper Tubings

5. Insert tubing connectors (E) into the lower tubings, aligning screw holes.
6. Secure tubing connectors to lower tubings using screws (F). Tighten with hex wrench.

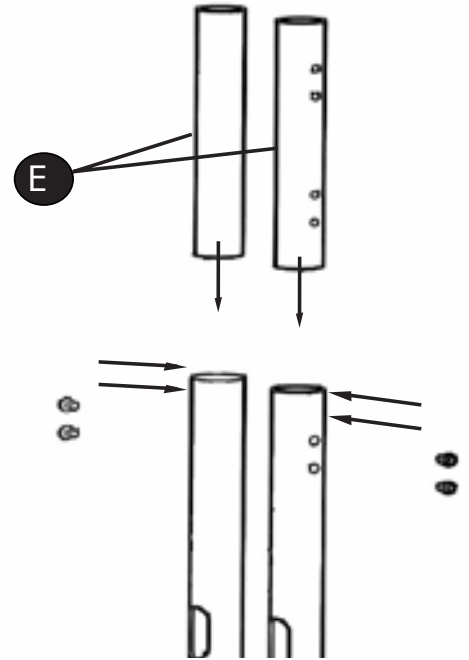

Upper Tubings with Connectors

7. Insert left and right upper tubings (D) into tubing connectors, aligning screw holes.
8. Secure to tubing connectors using screws (F). Tighten with hex wrench.

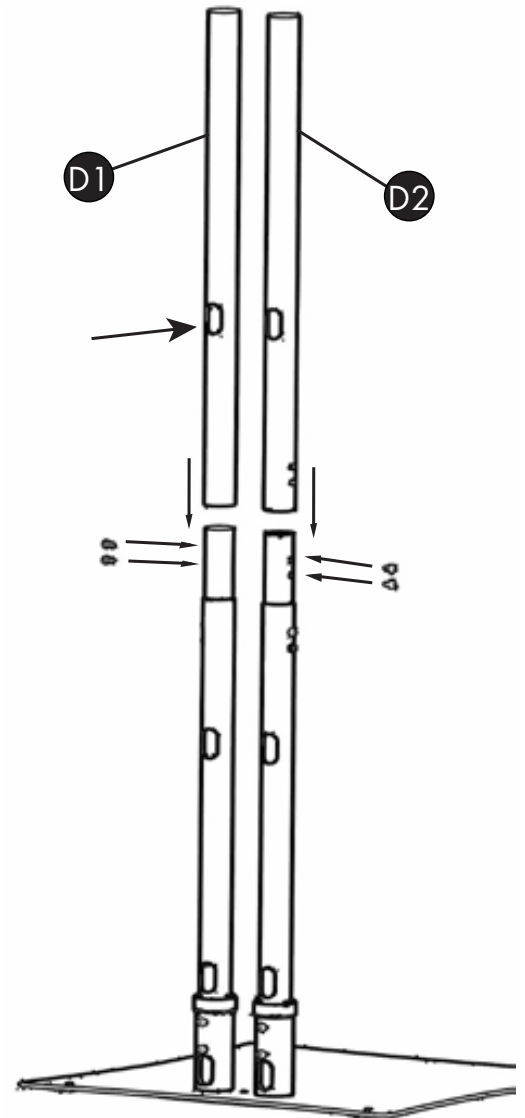

Securing Mount to Floor (Optional)

For added stability and security in public settings, the base can be bolted to the floor through the 4 holes in metal base.

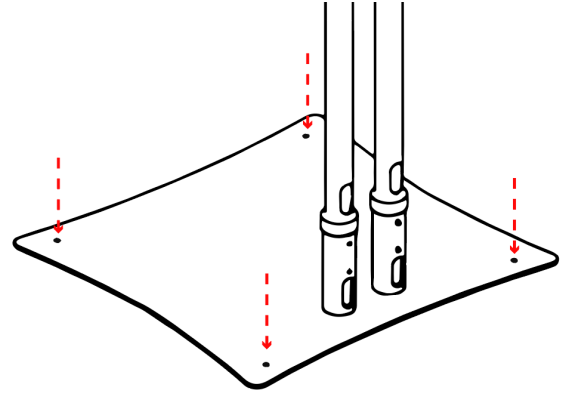

Installing Rotating Bracket

To install rotating bracket, refer to assembly instructions enclosed in the Mounting Bracket package (DUOPOLEBK).

- ! **NOTE:** The bracket locks all the weight of all compatible TVs in horizontal orientation. The bracket will only support TVs in portrait mode if the weight is under 15 pounds (6.8 kg).

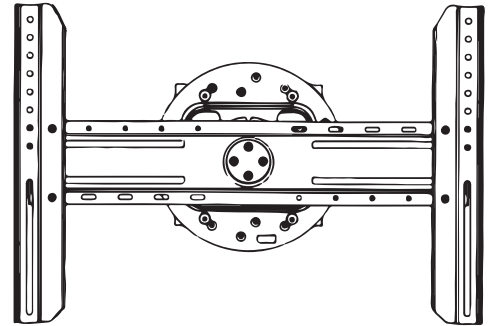

Assembly is complete.

See next page for guidance on installing Dual TV Stand with Two Rotating Brackets.

(DSTAND2BK, CDSTAND2BK)



Installing Dual Rotating Brackets (FOR DUAL HEAD TV STANDS ONLY)



! NOTE:

- DSTAND2BK can hold dual flat TVs up to 70", depending on different layouts and orientation. TVs can not be rotated while 2 TVs are hung on the stand at the same time.
- Be careful when using ladders or standing above the ground.
- Do not adjust the position of extrusion while TV is on the bracket.
- Do not use casters. Holes in the base are for mounting onto floor only.

Measure TVs

Lay the TVs in their intended position and measure the distance between the first VESA mount of each unit. This measurement is the **minimum** distance between each connector to ensure TVs will not interfere with each other.

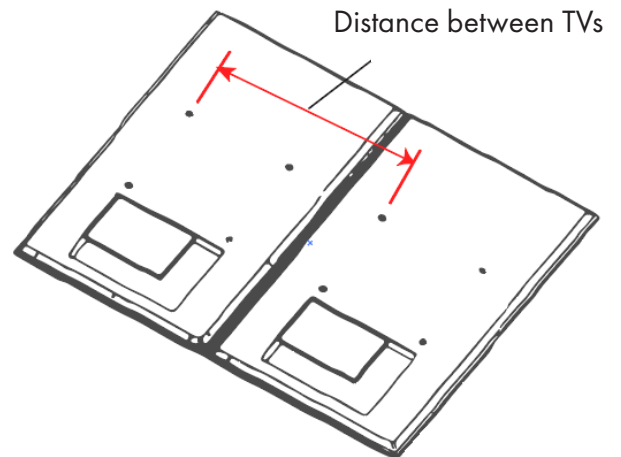

Add Dual Connectors

Use your measurements to determine position of 2nd connector set and attach the additional connectors at the marked location.

- ! NOTE: Do not place connectors over screws on poles.

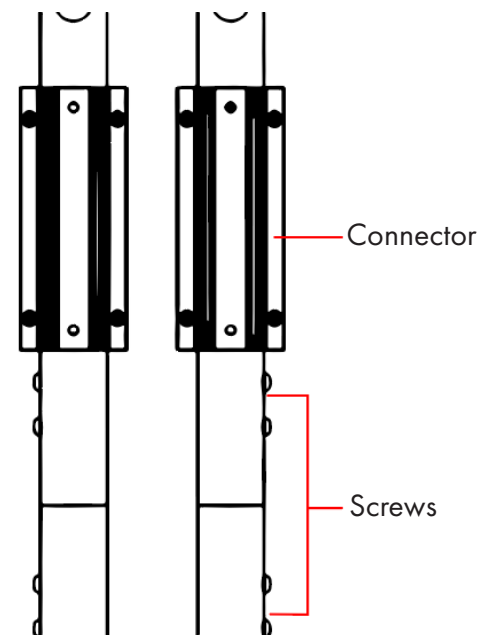
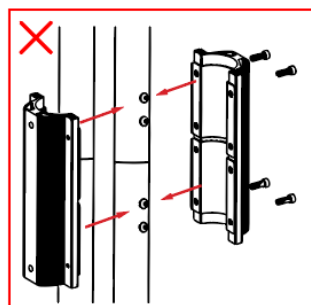

Mount Lower TV

First, mount the lower TV to the lower bracket. Feed power cord into pole and pull out through bottom slot.

(Refer to complete instructions in Mounting Bracket User Manual.)

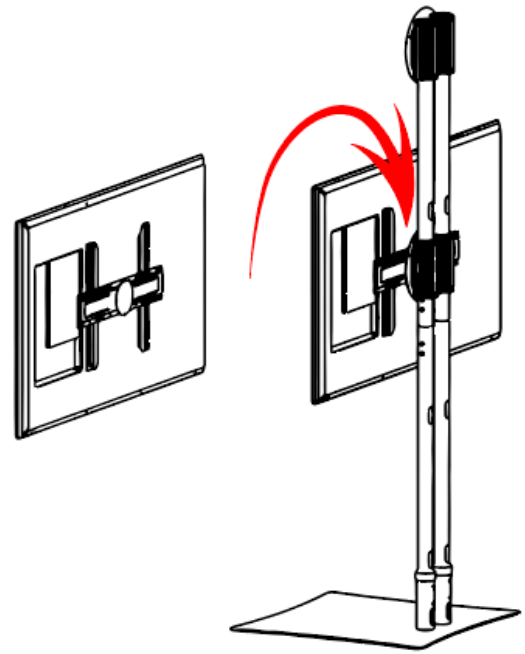

Mount Upper TV

Adjust spacing of upper bracket as necessary, then mount upper TV. Feed power cord into pole and pull out through bottom slot.

! **NOTE:** The bracket can be adjusted up and down on the TV to best fit the location of both TVs on the stand.

! Do NOT adjust the bracket position while the TV is mounted to the pole.

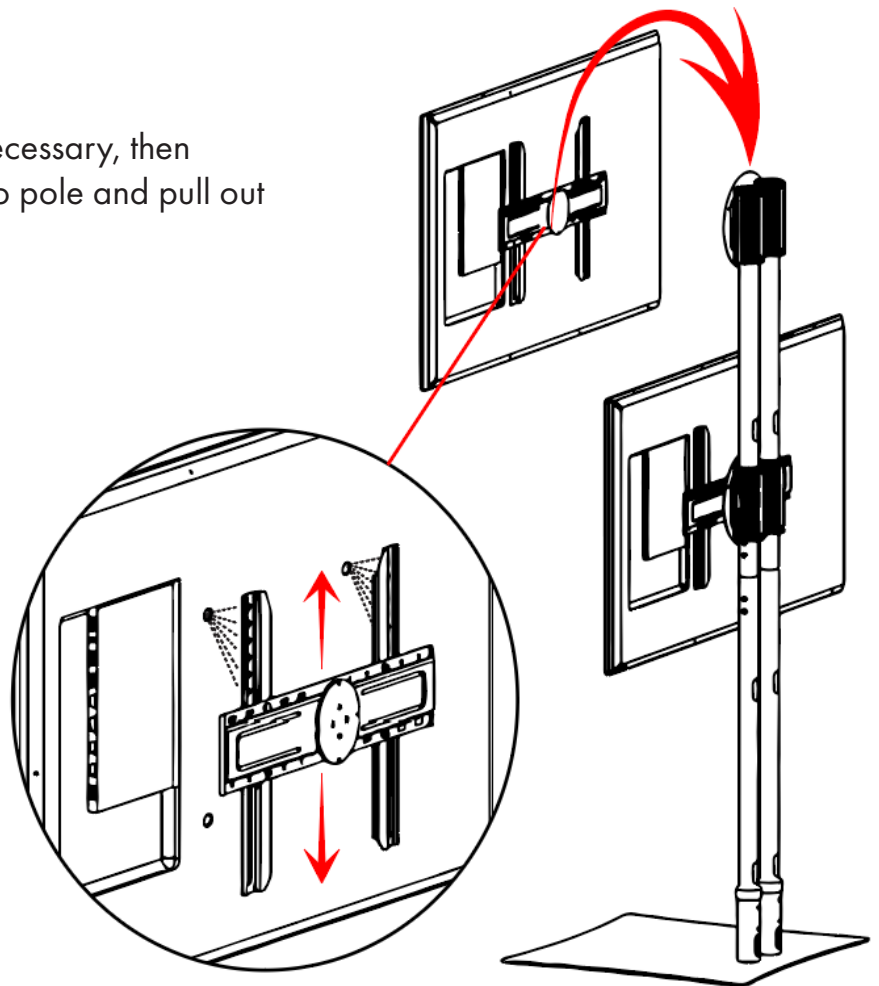

If you have any questions regarding our products, please visit us at www.displays2go.com or contact Displays2go customer service at 844-221-3388.